

ALU of GPS Processor

Cheuk Chon & Zhibin Wu

ALU Overview

- IEEE 754 format
- Floating point operations
 - Add/sub
 - Multiply
 - Divide
- Integer Arithmetic Unit
 - Add/sub
 - Multiply
 - Divide
 - Shift(Arithmetic and logical)

Divider in ALU

Zhibin Wu

Top-level diagram(floating point)

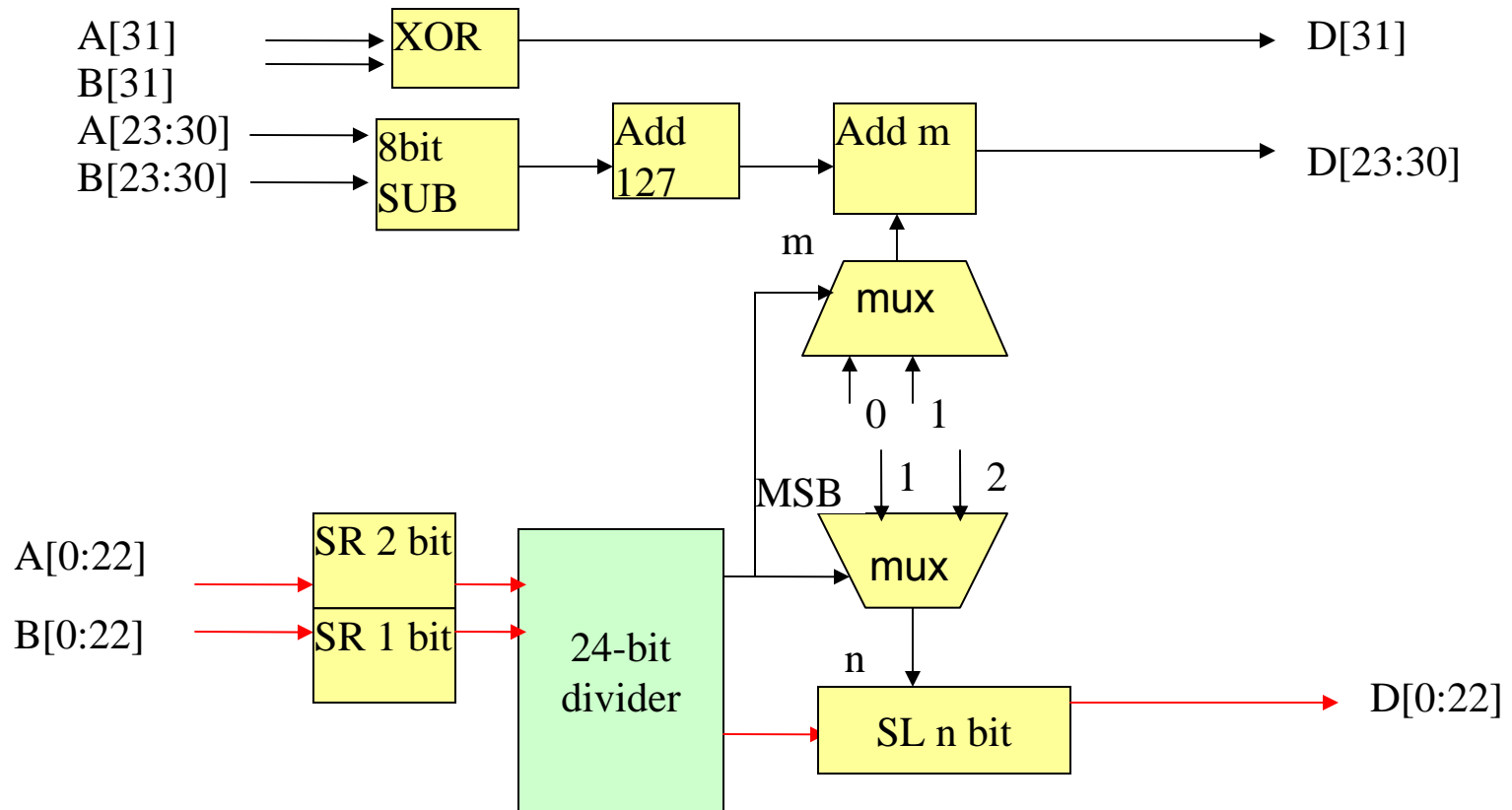

Integer Divider

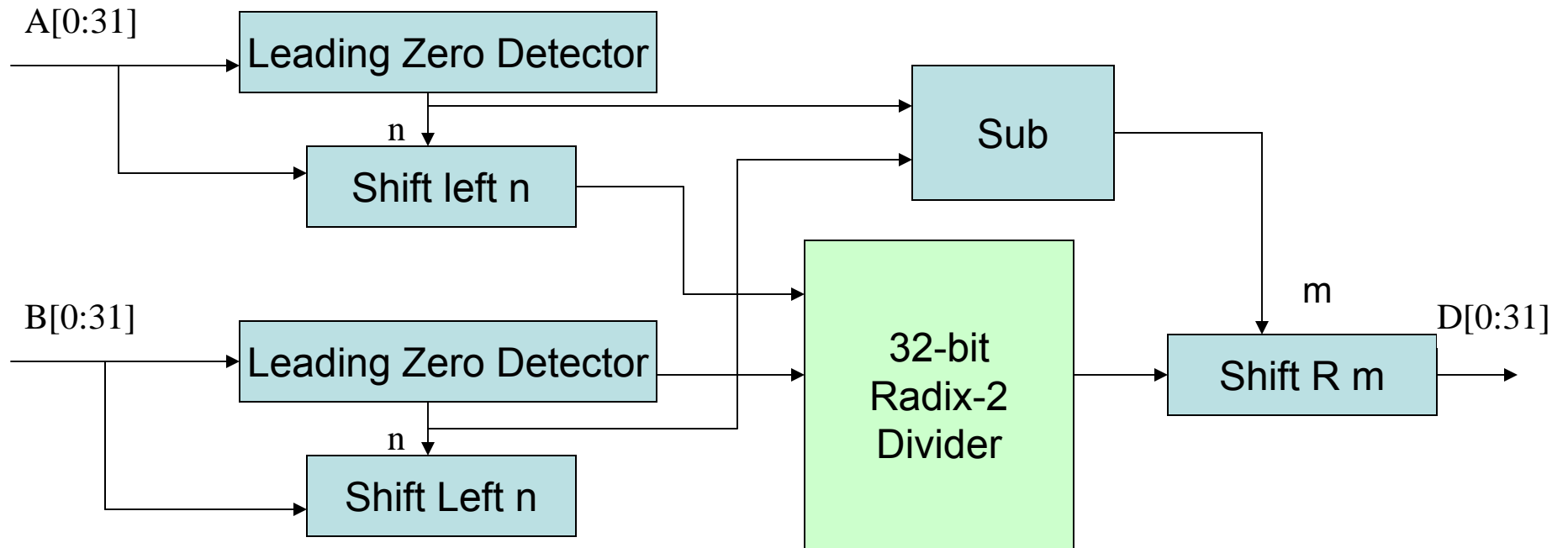

Radix-2 Divider

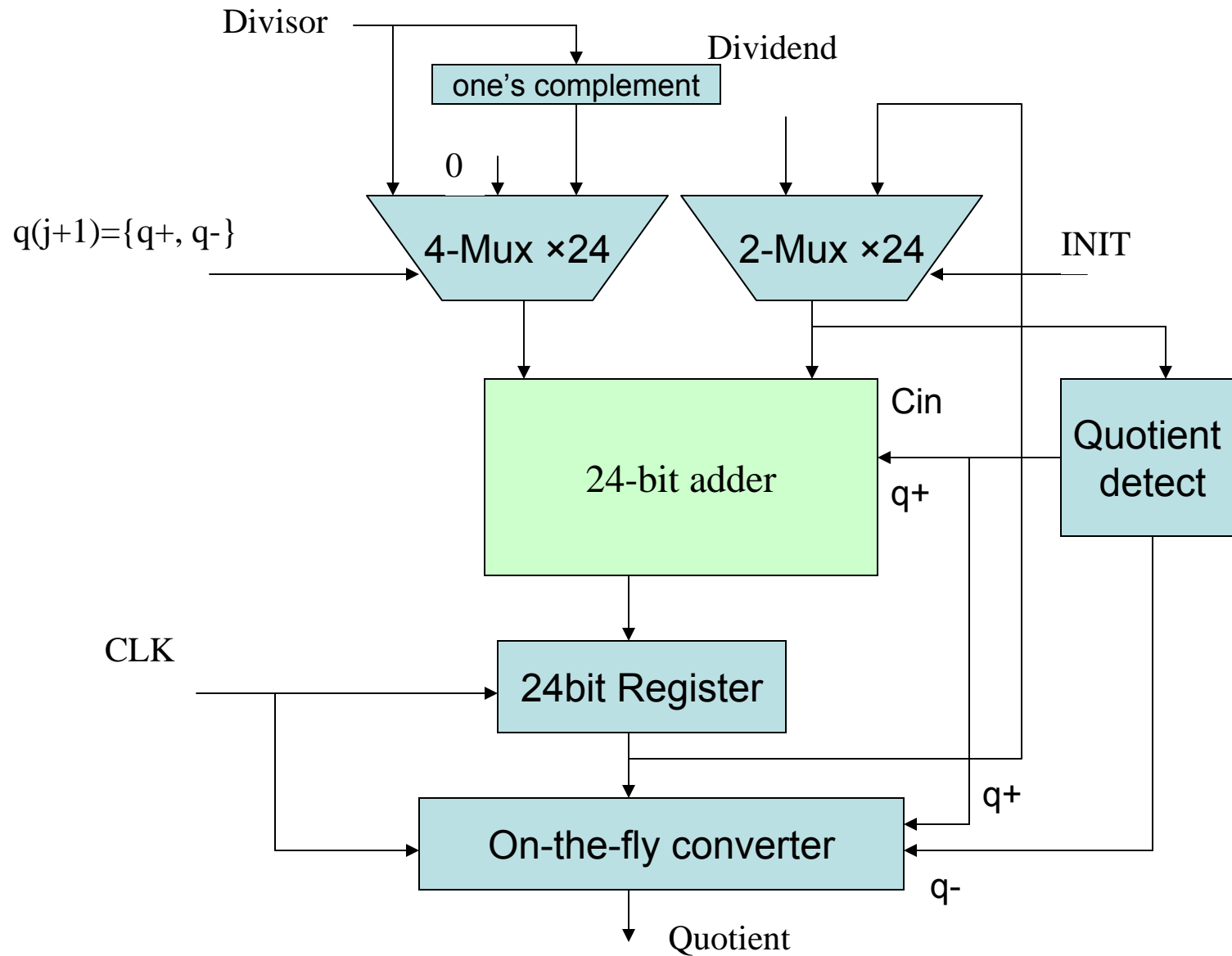

Chip Area

- Floating point divider
 - $0.225 \text{ mm} \times 0.225 \text{ mm}$
- Integer Divider
 - $0.27 \text{ mm} \times 0.27 \text{ mm}$
- 32 bit barrel shifter
 - $0.27 \text{ mm} \times 0.27 \text{ mm}$
- Divider use small area because a recursive algorithm is used
 - Trade off: area .vs. speed

Basic cell layout

- For reference
 - A one-bit full adder: $200\lambda * 100\lambda$
 - 1-bit Half adder : $100\lambda * 100\lambda$
 - Basic area for register: $200\lambda * 50\lambda$
 - Basic area for 2-to-1 mutiplexer: $50\lambda * 50\lambda$

Power Consumption Estimation

- From specification:
- One 8-bit full adder cost 0.9968mw
 - 24 bit full adder: 2.9904mW
 - 32 bit full adder: 3.9872mW
- Consider other components and duty 20%:
 - Floating point adder: <10mW
 - Integer divider: <8mW
- GPS project's specification has no low-power requirement.

Timing Analysis for Full Adder

- Carry-ripple adder delay
 - Basic on results for 8-bit carry ripple: 3.80ns
 - 24-bit carry ripple: 11.4ns
 - 32-bit carry ripple: 15.2ns
- CPU Clock: 10MHz, 100ns
- Full adder can perform the operation within one clock cycle.

Critical Path & delay

- For floating point divider
 - Mantissa part is not as slow as fraction part.
 - 24 clock cycles
 - Delay is 2400ns
- For integer divider
 - 33 clock cycles
 - Delay is 3300ns
- Delay is depend on the number of clock cycles, other delays can be neglected.

Testing strategy for ALU

- 64 inputs, impossible to exhaust all input patterns
- Strategy:
 - Random automatic test pattern generation
 - Specify some pattern to cover “exception” faults
- Adding Testability
 - Adding control pins to set internal state
 - Adding observability

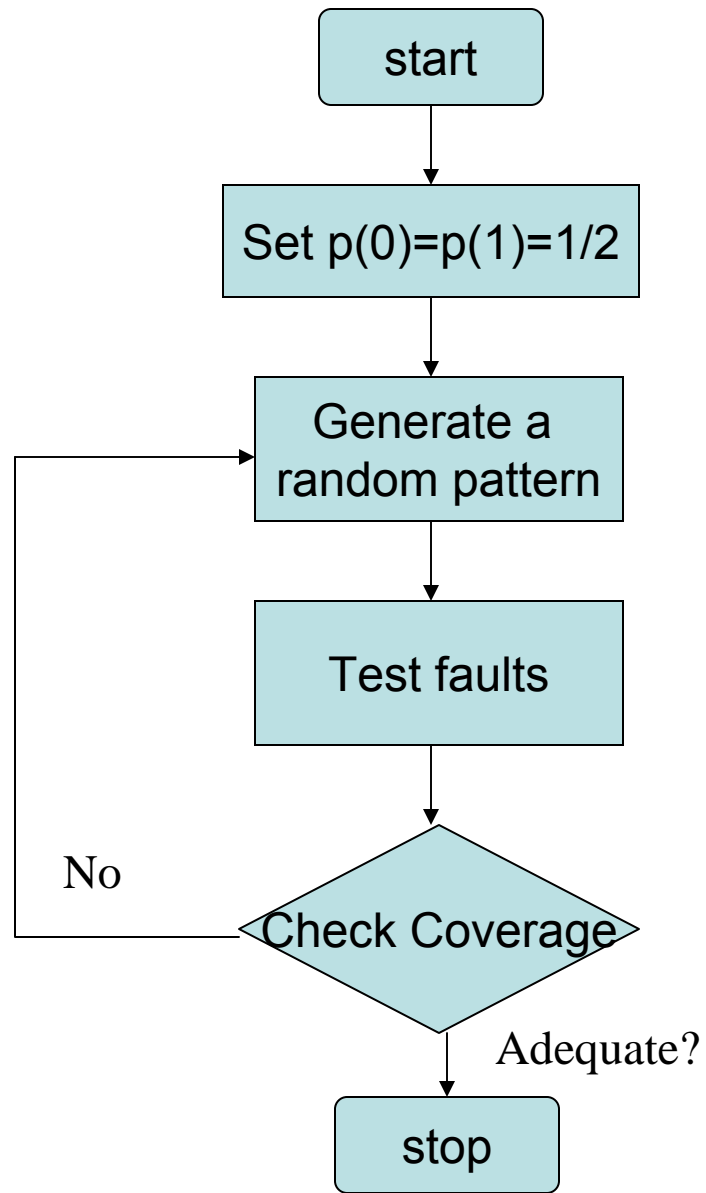

GPS

32 bits Floating Pointing Multiplier/
Adder/Subtractor

Cheuk Hon Chan

12/20/02

FPU Introduction

- Using IEEE 754 floating point format (single precision)
- Using booth algorithm for multiplier.
- Only need 12 rows of partial products to generate the result
- The area for multiplier is $0.7 \times 0.7 \text{ mm}^2$.
- The area for adder / subtractor is $0.4 / 0.4 \text{ mm}^2$.
- The unit is very fast.

32 Bits Floating Point Multiplier

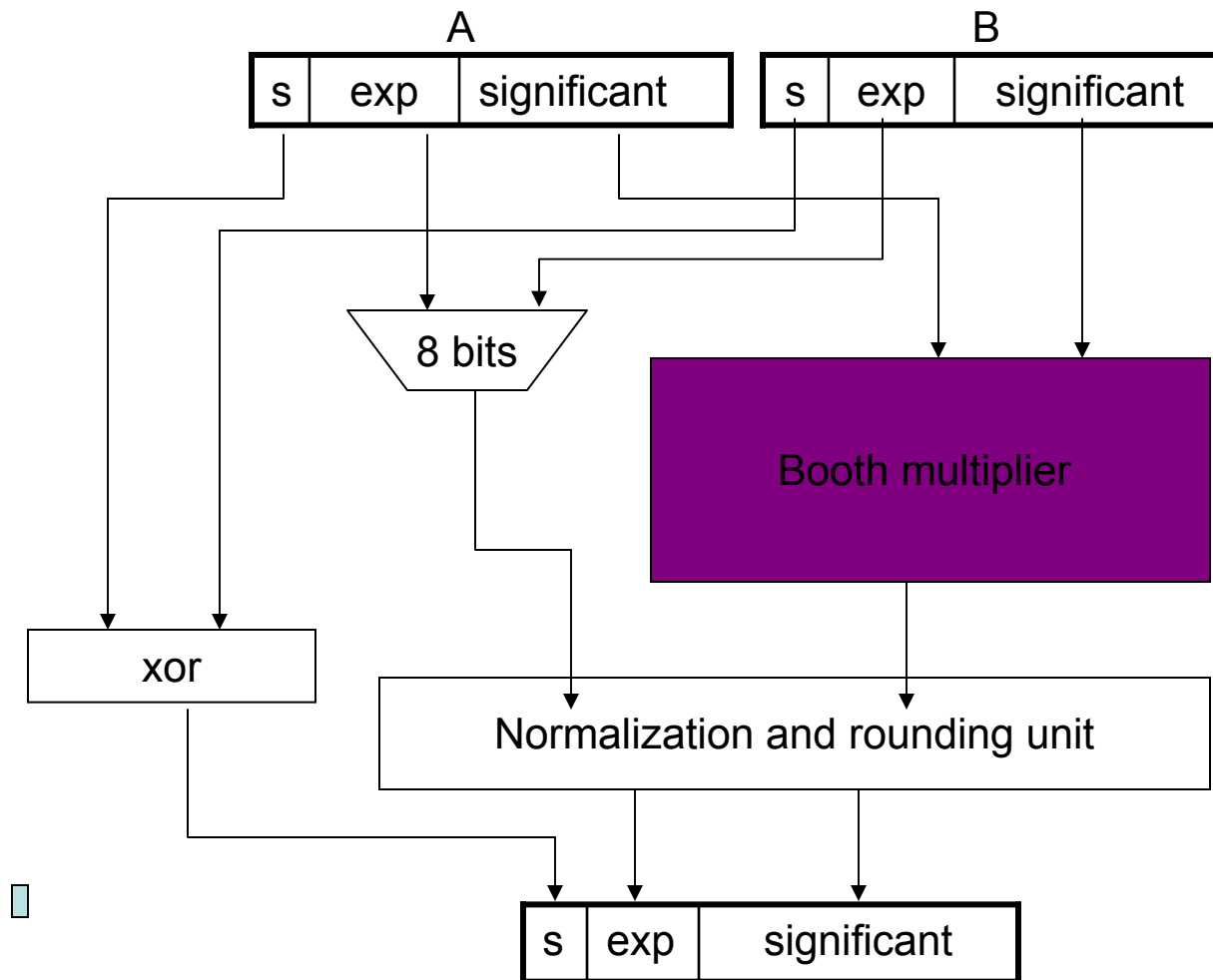

Floating Point Multiplier

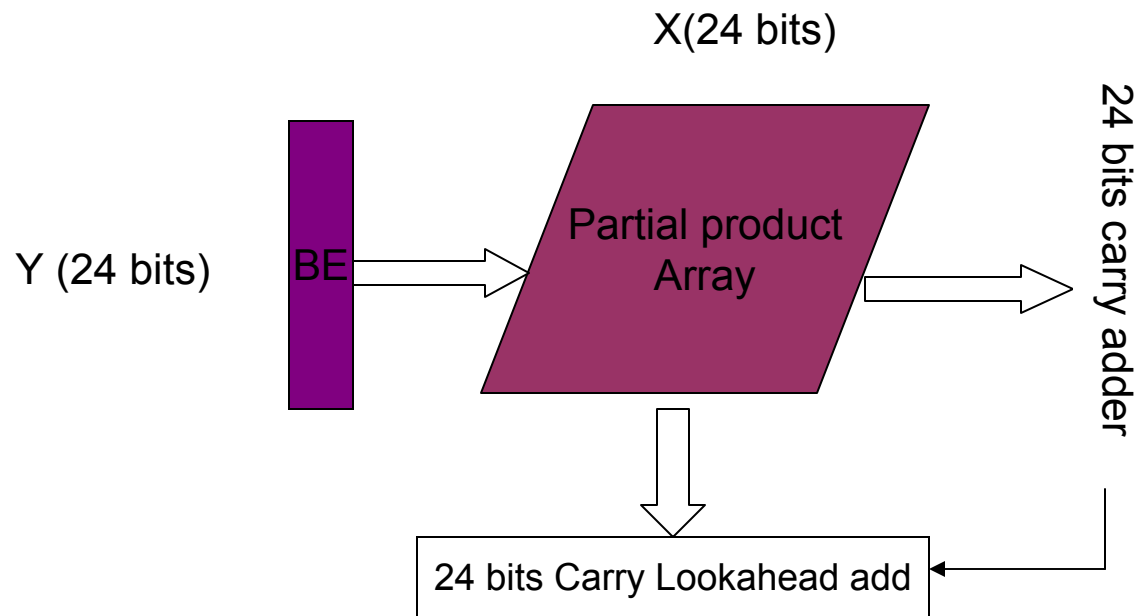

Booth Multiplier – Booth encoder

Y_{i+1}	Y_i	Y_{i-1}	Encoded digits	Explanation
0	0	0	0	Add 0
0	0	1	+1	Add x
0	1	0	+1	Add x
0	1	1	+2	Shift left x by one digit and add
1	0	0	-2	Add 2's complement of x and shift left by one digit
1	0	1	-1	Add 2's complement of x
1	1	0	-1	Add 2's complement of x
1	1	1	0	Add 0

8 bits Booth Multiplier

Power Consumption

The power for a 8 bits carry-lookahead adder is 0.996 mW.

A 24 bits carry-lookahead adder is 3.9 mW.

One full adder in booth multiplier block is 88 μ W.

One half adder in booth multiplier block is 20.56 μ W

Each mux block is 9.7 μ W.

Each booth encoder (BE) block requires 0.4 mW.

The whole booth multiplier block is 7.8mW.

The floating point multiplier consumes 11.3 mW

Timing analysis

- A 8 bits carry lookahead adder is 1.3 ns.
- A 24 bits carry lookahead adder is 4 ns.
- Each full/half adder block in booth multiplier is 0.7 ns.
- Each mux block in booth multiplier is 0.35 ns.
- Each booth encoder unit is 0.29 ns.
- The booth multiplier block is 12.05 ns.
- The floating point multiplier is 16.25 ns.

32 bits Floating Adder / Subtractor

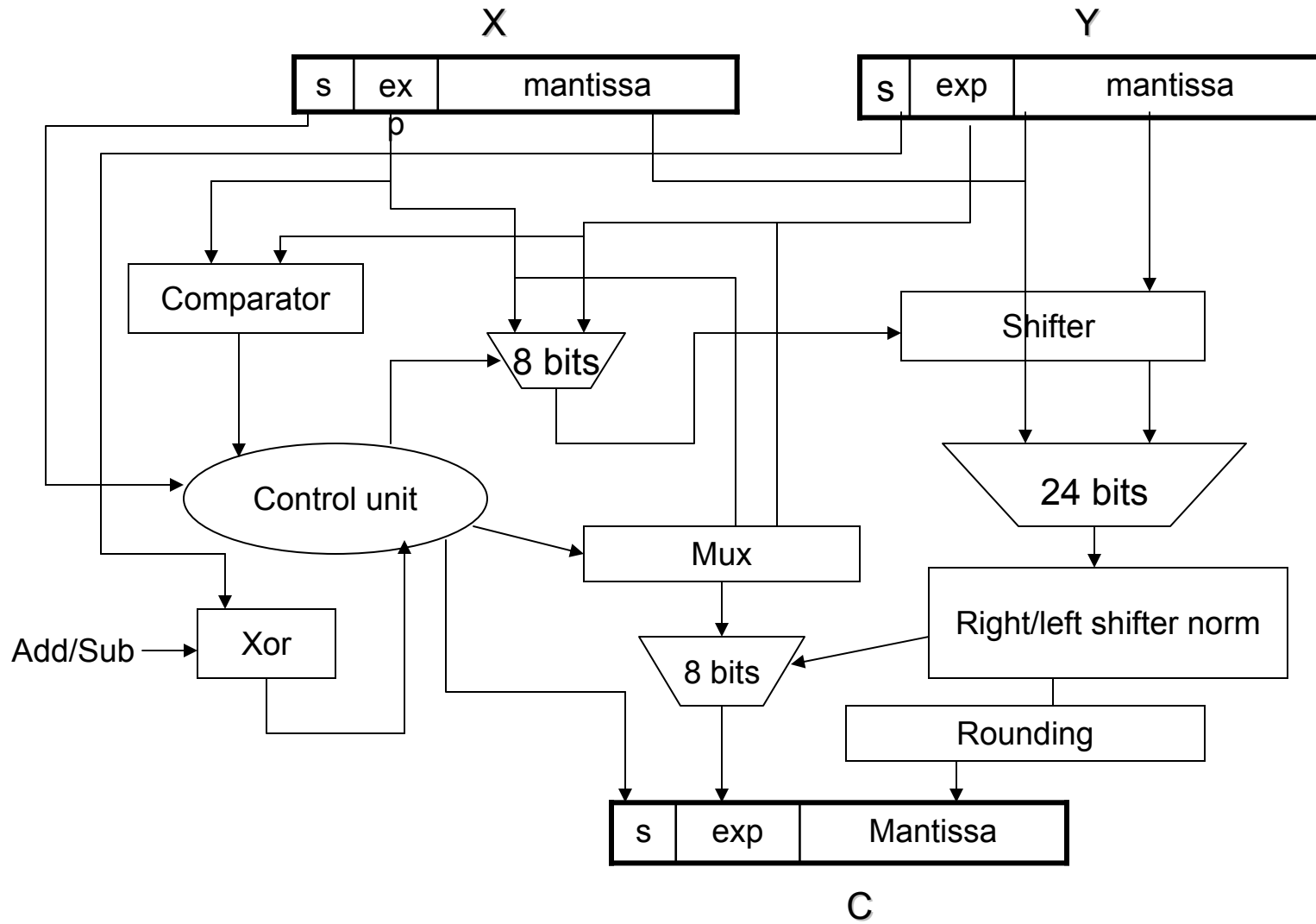

Power Consumption / Timing analysis

- A 8 bits comparator needs 0.650 mW.
- Then, a 24 bits carry-lookahead adder is 3.9 mW.
- The floating point adder/subtractor is 9.65 mW.
- The comparator is 1.24 ns.
- A 24 bits carry lookahead adder is 4 ns.
- The whole floating point adder/subtractor is 9.65 ns.

Conclusion

- The overall area for ALU is 2mm x 2mm.
- The total power consumption < 40 mW
- The ADD SUB, SHIFT, MULTIPLY instruction is done within one clock cycle.
- The DIV is using the multiple clock cycles to perform the operation
- The main test method for ALU uses ATPG.